

TTR 200 / TTR 300

EN

OPERATING MANUAL
ADSORPTION DEHUMIDIFIER



Table of contents

1. Notes on how to use the manual.....	2
Description of symbols.....	2
Typographical conventions.....	2
2. Scope of delivery.....	2
3. Warranty.....	2
4. General safety instructions.....	3
5. Proper use.....	3
6. General information.....	3
Functional principle.....	4
7. Description of device.....	4
Structure and components.....	4
Optional accessories.....	5
8. Set-up and commissioning.....	5
Set-up.....	5
Installation.....	5
Presettings.....	5
9. Operation.....	5
Switching the device on.....	5
Switching the device off.....	5
Remote operation.....	5
Air volume adjustment.....	5
10. Transport and storage.....	6
Transport.....	6
Storage.....	6
11. Care and maintenance.....	6
Care.....	6
Maintenance.....	6
Replacing the filter.....	6
12. Dangerous substances.....	6
13. Disposal.....	7
Dehumidifier.....	7
Packaging.....	7
14. Service and repair.....	7
15. Troubleshooting.....	8
16. Technical data, Spare parts.....	8

1. Notes on how to use the manual

Translation of the original instructions (2006/42/EC):

This operating manual contains all important information required for safe commissioning and use of the device.

It provides you with support for operating the device and remedying possible problems as well as with information on disposal and customer service.

Please read this manual thoroughly and completely before using the device for the first time.

Please store this operating manual and keep it within reach in order to consult it if necessary.

Please observe all safety instructions and information on use and maintenance contained in this manual.

This manual should be attached to the device if the latter is made available to other persons for use.

Description of symbols



WARNING SYMBOL. This symbol is followed by hazard warning instructions whose non-compliance may cause serious injuries and/or death and/or property damage.

The note is always preceded by a signal word:

Risk: Risk of serious or fatal injury

Warning: Risk of serious permanent injury

Caution: Risk of damage to property



Additional information which might be helpful when using the device.

Typographical conventions

All text references to figures refer to the figures in the respective chapter. Position numbers that are not available in the respective chapter may refer to figures in the chapter "Description of device".

2. Scope of delivery

The scope of delivery of the device includes:

- Dehumidifier
- Connection cable
- Operating manual

Further optional accessory parts can be ordered from the Trotec customer service.

3. Warranty

Any damage to the device resulting from non-compliance with the instructions contained in this manual shall be excluded from the warranty.

The manufacturer shall assume no liability for damages to the device and/or its accessories that are caused by unauthorised modifications.

4. General safety instructions



Please observe the following safety instructions!

Any non-compliance with these instructions may have serious consequences for the health of persons and could result in property damage and damage to the environment.

Risk of explosion!

- Do not operate the device in potentially flammable or explosive environments. Do not install it in such environments, either.

Only devices approved according to directive 94/9/EC (ATEX 95) may be operated in explosive environments. It is the obligation of the operator to check the operational capability of the dehumidifier according to directive 1999/92/EC (ATEX 137)!

- Do not place the device on flammable surfaces.
- Remove any inflammable materials and chemicals from the immediate operating environment.

Functional impairment of and damage to the device!

- Install the device in a stable position on a firm surface.
- Protect the device from adverse weather effects.
- Keep the intake and exhaust openings free.
- Do not cover the device during operation.
- Do not use any chemicals when cleaning the device.
- Never place items on the device or step on it.

Risk of injury and damage to property due to defective devices!

- Before each use of the device, check its accessories and connection parts for possible damage. Do not use any defective devices or device parts.
- Do not use the device if you discover any damage to its plug and cables. Defective power cables represent a serious health threat.

Danger to life through electrical shock!

- Only connect the device to power sources that are in good technical order. Do not use damaged wall outlets!
- Pull the connection cable out of the wall outlet by pulling it at its plug.
- Do not touch electrical connection cables when your hands are wet!
- Protect electrical connection cables against damage caused by, for example, animals.
- Do not carry out any changes or repairs on the device!
- Do not expose the device to any liquids.

- Do not let any liquids enter the device. If this does happen nevertheless, pull out the power cord and have the device checked and/or repaired by the Trotec customer service.
- The device may only be opened, cleaned on the inside and repaired by authorised and appropriately trained personnel.

Risk of injury!

- Do not insert any objects into the intake and exhaust opening of the device.
- Do not remove any personnel protection devices against accidental contact.
- Do not reach into the openings of the device.
- Do not leave children or animals unattended near the operating device!
- Wear a hairnet to prevent long hair from getting into the device.
- Take off any jewellery before operating the device.
- Always wear safety goggles to protect your eyes.
- After decommissioning the device, let it cool down for 5 minutes before touching it to avoid burns. Wear protective gloves.

5. Proper use

The dehumidifier may exclusively be used to dehumidify atmospheric air. Any other use is considered as improper use. Any liability for damage resulting from this is excluded.

Dehumidifiers may not be installed in liquids nor take in any liquids (e.g. from tanks, tubs or flooded areas, etc.).

Proper use also includes:

- Adherence of all notes contained in the operating manual and
- Fulfilling inspection and maintenance requirements.

Any use other than the above-mentioned uses shall be inadmissible!

6. General information

Dehumidifiers according to the adsorption principle are used for drying applications in process engineering, air conditioning, on construction sites and for dehumidifying manufacturing and storage areas where products and installations require particularly low air humidity.

Adsorption technology enables lower dew points and, particularly at intake temperatures < 0 °C or intake dew points < 5 °C, safe dehumidification that cannot be achieved with condensation dehumidifiers for physical reasons. Additionally, adsorption dehumidifiers are considerably more economic at these operating temperatures.

Functional principle

Adsorption dehumidifiers work with a drying wheel (rotor) consisting of layers of flat and corrugated fibres with a chemically bound silica gel. This generates a honeycomb structure with numerous axial air channels with a large surface and direct connections to the inner pore structure of the silica gel.

Due to the favourable mechanic and physical properties of the drying wheel, no silica gel is released and can be subject to saturated air (100% rh), however, not to drips of water. It is not flammable.

The basic design of a dehumidification unit is as follows:

- Fan(s) for air delivery
- At least two different sections for delivery of process air (to be dehumidified) and regeneration air (humid exhaust).
- Drying wheel for dehumidification
- Drive unit with gear motor, toothed belt disc and toothed belt
- Heating unit for heating of the regeneration air

During dehumidification, the drying wheel continuously turns at low speed (3 to 30 rpm, depending on the configuration). This way, process air and regeneration air are simultaneously applied to the drying wheel via the sections so that it can permanently absorb and release humidity.

Process air

Air to be dehumidified is taken in by means of a fan. The process air (4) flows through the dehumidification section (1) of the drying wheel. In this process, the humidity in the air is removed by means of the sorbent (silica gel) and bound (adsorption). Due to physical processes, the temperature of the drying air is increased. In the further process, the dried air (6) is delivered to the drying air outlet. A small portion of the flow is separated in the device as regeneration air.

Regeneration air

The heated and dried regeneration air reduces the heating energy demand and supports regeneration of the drying wheel. When flowing through the heating unit (7), the temperature of the air is increased to approx. 100 - 120 °C (depending on the intake temperature), while its relative humidity is considerably reduced.

Afterwards, the air that was prepared in this process absorbs the humidity bound in the silica gel (desorption) when passing the regeneration section (2). Afterwards, the extremely humid regeneration air (8) is delivered outside through the humid air outlet.

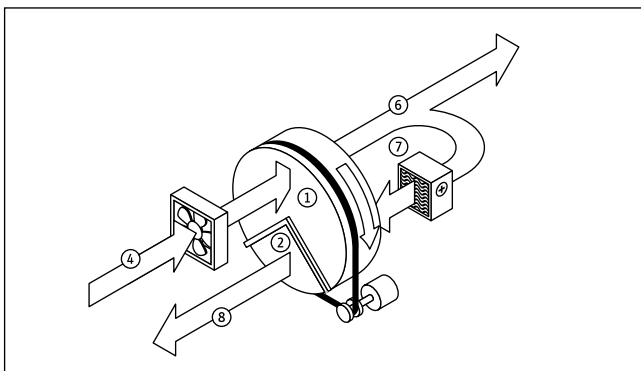

Fig.: Functional principle

7. Description of device

Structure and components

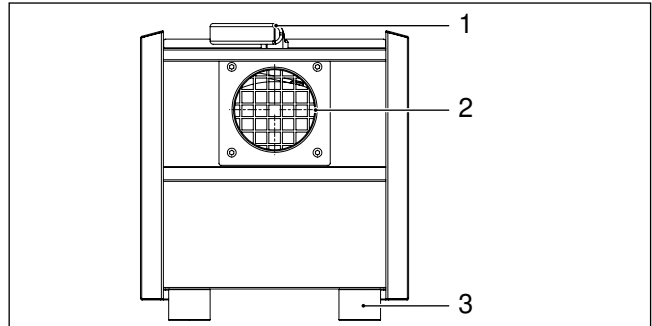

Fig.: Front side

- 1 Handle
- 2 Drying air outlet
- 3 Device feet

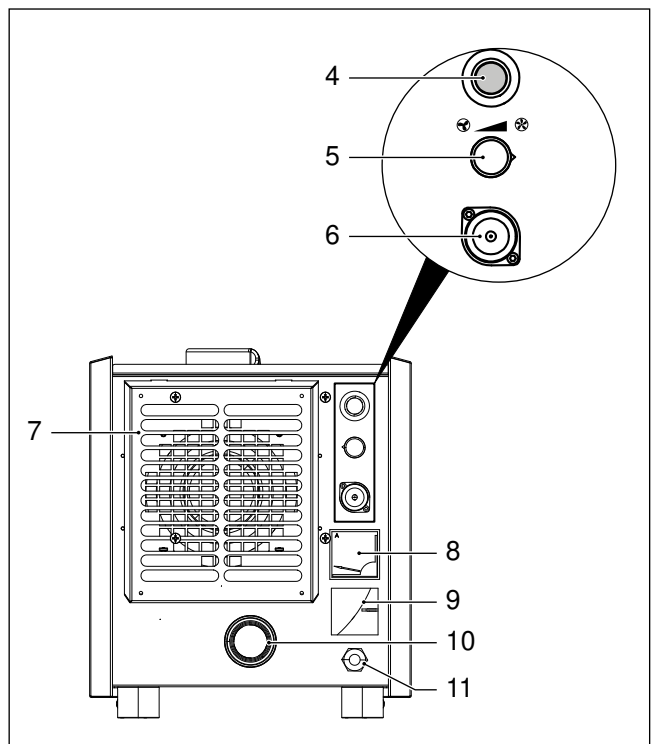

Fig.: Rear side

- 4 Power switch
- 5 Fan speed controller
- 6 Connection of external hygromat
- 7 Intake cover coarse dust filter
- 8 Ampere meter
- 9 Operating hour counter
- 10 Humid air outlet
- 11 Connection cable

Optional accessories

For operation of the dehumidifier, the following accessories are available:

- Hose adapter for installation at the intake cover (7)
- Air filter box with tube/hose port for Z line filter G4 to F9
- Drying air diffuser, triple
- Hygrostat with Tuchel plug for connection socket (6)
- Combined meter for operating hours and energy consumption (only TTR 300)

For the technical data and order conditions, please contact the Trotec customer service.

8. Set-up and commissioning

Set-up

a) Inside the room to be dehumidified:

The device works with air circulation. The regeneration exhaust air is to be released outside. This proportion must be balanced by supplying fresh air into the room.

b) Outside the room to be dehumidified:

The device can be connected in air circulation or through-air operation mode. In this respect, connection must be established between the drying air and the room to be dehumidified. Also here applies: In air circulation operation, the proportion of regeneration air must be balanced with fresh air.

Installation

- The pipelines or hoses must be designed for the applied static pressure by the fans. Air hoses are to be laid out in a straight line and outstretched.
- The regeneration exhaust air line must be laid out with a slight slope to prevent potential condense water from flowing back into the device or disturbing the air flow. If the air line is to be laid out in a rising direction, a discharge is to be provided for condense water. As a precautionary measure, the exhaust tube can be insulated.
- To prevent an air short circuit with the humid exhaust air, the humid air outlet of free-intake devices is to be laid away at a minimum distance of approx. 1.0 m from the device.

Presettings

Ventilation devices are generally equipped with one or several fans with sufficient dimensions to overcome resistance in potential pipelines or appliances. In most cases, their speed cannot be adjusted. To set the required air flow for the respective application, the hydraulic adjustment is to be carried out by means of throttle valves installed downstream and upstream of the fan. However, this leads to an unnecessary and often considerable increase in noise and energy consumption.

This device is equipped with a **variable-speed high performance fan** to supply the nominal drying and regeneration air flows at maximum speed with connected air hoses (each approx. 6 m long).

Additionally, the device features a heating unit generating heat by means of ceramic PTC semiconductor components to heat the regeneration air. These elements generate and keep a maximum surface temperature of approx. 240 °C. The temperature-dependent resistance, which increases

quickly with decreasing heat distribution under a certain value (Curie temperature), leads to a self-regulating effect of the heating power consumption, i.e. in case of an increase in air temperature and/or decrease in air volume, the power consumption decreases (and vice versa). Additionally, destruction of the device by overheating, e.g. due to a lack in regeneration air, can be excluded.

Due to its design, the device is only equipped with one fan for both flows. For this reason, the speed adjustment of the fan may not be sufficient. In this case, additional measures must be taken to fine-tune the flows in the tube/hose lines.

To achieve **minimum humidity outlet** at minimum drying air or **maximum dehumidification performance** at maximum drying air, it is crucial to appropriately adjust the volume of regeneration air. The air volume must be adjusted until the value defined as **optimum heating flow** is displayed at the ampere meter.

For all other applications with low requirements placed on the dehumidification performance and drying air volume, the speed of the fan can be reduced until the value defined as **minimum heating flow** is displayed at the ampere meter. This way, very good dehumidification results can be achieved at minimum energy consumption.

9. Operation

Switching the device on

The device can be switched on at the power switch (4). The integrated control indicator will light up.

Switching the device off

The device can be switched off at the power switch (4). The integrated control indicator will go out.

Remote operation

The device can be switched on at the power switch (4). The integrated control indicator will light up.

Use the respective Tuchel plug (optional accessory) to connect an external switch or control unit, e.g. hygrostat or timer, to the connection socket. Please strictly follow the information in the attached circuit diagram!

If necessary, all electrical actuators can now be switched on or off by means of the external switch. The control indicator on the power switch keeps flashing irrespectively of the switching position and indicates that the control system is activated.

In hygrostat operation, it may be necessary to provide air circulation at the humidity detection position. In this case, the fan can be configured for permanent operation by repositioning a plug at the integrated relay. This operation may only be performed by a trained electrician. If necessary, please contact the Trotec customer service.

Air volume adjustment

The fan speed can be adjusted at the speed controller (5). Turn the controller to the right to increase the air volume and to the left to decrease it.

10. Transport and storage

Transport



Caution!

Damage to device due to vibrations.
 Strong vibrations can cause damage to the device.
 When transporting the device, protect it from excessive shocks, e.g. by rough handling or dropping.
 During transport, always secure the device against slipping.
 Lift and carry the device only by using the provided means.

Storage

Store the device in a dry place where it is protected from adverse weather effects.
 Choose a storage location that is free of dust.
 Always disconnect the device from the mains supply when it is not in use.
 Up to 4 devices can be stacked in a space-saving way.
 Always secure stacked devices against tipping.

11. Care and maintenance

Care

The housing surface of the device comes with a low-maintenance powder coating. This decreases the adhesion of dirt and enables cleaning with a damp piece of cloth.
 Cleaning of the interior and the integrated components may only be carried out by trained personnel or the Trotec customer service.



Caution!

Damage to the device due to improper cleaning.
 The interior of the device must only be cleaned with a damp cloth or pressurised air. Do not let any liquids enter the device!

Maintenance

Trotec dehumidifiers are designed for long operating hours with low maintenance requirements. To ensure safe operation of the device, all integrated components must be checked and cleaned or replaced **at least once every 6 months or 4,000 operating hours** if necessary.



Caution!

Damage to the device due to improper handling.
 Cleaning, maintenance and repair of electric and mechanical components may only be carried out by trained personnel or the Trotec customer service.

Replacing the filter

The intervals for replacing the filter depend on air contamination and filter quality. Contaminated filters affect the efficiency of the humidifier. For this reason, filters should be checked and cleaned or replaced **once every week (daily on construction sites)** if necessary.



Danger!

Risk of injury at the fan.
 Before removing the air filter, the device must be switched off and secured against accidental activation, particularly if the fan inlet is freely accessible!

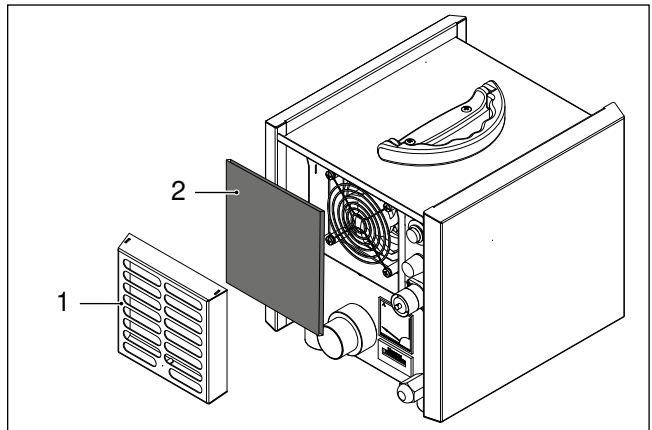

Fig.: Air filter replacement TTR 200/300

- 1 Filter cover
- 2 Filter mat

To remove the filter mat (2), the filter cover (1) must be released by pulling it with a slight jerk.

By default, all devices are equipped with a reusable filter mat. This mat can be cleaned by beating or washing it.



Caution!

Damage to the device due to liquids.
 Before inserting the air filter, always ensure that it has dried completely. Otherwise, there is the risk that the fan takes in liquids and is damaged due to a short circuit.

12. Dangerous substances

When operating the dehumidifier in rooms that are contaminated by certain chemical substances, the dehumidification unit (rotor) may be damaged permanently. The substances remain in the rotor and may deteriorate the performance of the device by clogging the silica gel pores or lead to chemical reactions of the gel.

This permanently affects the performance and service life of the dehumidifier.

For this reason, it must be ensured, that the applied dehumidification agent, i.e. the silica gel, cannot come into contact with dangerous substances.

The following list includes substances with a proven deteriorating effect on the dehumidification rotors (silica gel) used in this device. Even small quantities of these or similar substances must be prevented from coming into contact with the device.

Inorganic substances

Lithium chloride	LiCl	Deterioration of the performance
Sodium hydroxide	NaOH	Destruction of the silica gel structure
Potassium hydroxide	KOH	Destruction of the silica gel structure
Sodium chloride	NaCl	Deterioration of the performance
Potassium chloride	KCl	Deterioration of the performance
Calcium chloride	CaCl ₂	Deterioration of the performance
Magnesium chloride	MgCl ₂	Deterioration of the performance
Ammonia	NH ₃	Deterioration of the performance
Hydrofluoric acid	HF	Destruction of the mech. stability
Aluminium chloride	AlCl ₃	Deterioration of the performance
Sea water		Deterioration of the performance
Steam with high temp.		Destruction of the silica gel structure
Softener		Clogging of silica gel pores
Strong acids	pH ≤ 2...3	Destruction of the mech. stability
Bases	pH ≥ 7...8	Destruction of the sorption capacity of the silica gel
Amines	R-NH ₂	Deterioration of the performance

Organic substances

Oil mist		Clogging of silica gel pores
Cyclohexanone	C ₆ H ₁₀	Deterioration of the performance
Isopropyl alcohol	(CH ₃) ₂ CHOH	Deterioration of the performance
o-Xylene	C ₆ H ₄ (CH ₂) ₂	Deterioration of the performance
m-Xylene	C ₆ H ₄ (CH ₂) ₂	Deterioration of the performance
p-Xylene	C ₆ H ₄ (CH ₂) ₂	Deterioration of the performance
Phenol	C ₆ H ₅ OH	Deterioration of the performance
o-Dichlorobenzene	C ₆ H ₄ Cl ₂	Deterioration of the performance
Methyl bromide	CH ₃ Br	Deterioration of the performance
Glycerine	C ₃ H ₈ O ₃	Deterioration of the performance

Additionally, the air that is taken in by the device must not contain any substances with melting points below 200 °C!

Immediately before commissioning the dehumidifier, the following requirements must be fulfilled:

- The dehumidifier may only be used according to the parameters specified in chapter "Technical data".
- Make sure that the air inlet and air outlet (drying air and humid air) are not covered.
- Check if all filters as well as covers and protective grids are in place and tightened. All screw connections must be checked for tightness.

13. Disposal

Dehumidifier

Electronic equipment may not be disposed of in the domestic waste but must be correctly disposed of in the European Union in accordance with the EUROPEAN PARLIAMENT directive 2002/96/EC of 27th January 2003 regarding used electrical and electronic equipment. Please dispose of this device after its final decommissioning according to the applicable legal regulations.

Packaging

The packaging of the device consists of cardboard/paper and plastic. The materials must be disposed of in the designated containers according to local regulations or at a recycling depot.

14. Service and repair



Danger!

Danger to life due to improper repair

Never attempt to carry out modifications or repairs on the device. Any unauthorised modification may result in serious injuries or even death. Have repairs carried out by a certified specialist workshop.

Repairs may only be carried out by trained specialists!

Before contacting our customer service in order to solve an existing technical problem, please try first to rule out errors due to improper use or application.

If you have any further questions regarding function and operation of the dehumidifier or if you wish to receive further information in the event of an error or with regard to warranty aspects, please do not hesitate to contact us at any time.

Please contact:

Trotec GmbH & Co. KG
Grebbeener Straße 7
D-52525 Heinsberg

Tel.: +49 (0) 2452 / 962-400
Fax.: +49 (0) 2452 / 962-200
E-mail: info@trotec.de

www.trotec.de.

15. Troubleshooting

Error	Diagnosis	Possible cause	Remedy
No dehumidification	Drying air does not show any temperature increase	Rotor drive defective	Check the rotor drive and repair if necessary
	Ampere meter displays considerably deviating values	Heating unit defective	Replace heating unit
	Ampere meter displays deviating values	Insufficient regeneration air flow	Check free air flow, check fan, clean or replace the air filter

16. Technical data, Spare parts

Parameter	Value*	
	TTR 200	TTR 300
Article number	1.110.000.010	1.110.000.015
EAN number	4.052.138.007.464	4.052.138.007.471
Dehumidification performance	0.35 kg/h	0.68 kg/h
Range of application for drying air	40 ... 120 m ³ /h	80 ... 280 m ³ /h
Nominal air volume/pressing	80 m ³ /h / 50 Pa	200 m ³ /h / 100 Pa
Regeneration air volume approx.	15 m ³ /h / 30Pa	30 m ³ /h / 50Pa
Intake temperature	-15°C ... +35°C	-15°C ... +35°C
Ambient temperature	-20 ... +40°C	-20 ... +40°C
Power connection	230V - 50/60Hz	230V - 50/60Hz
Overall power consumption	0.45 kW	0.90 kW
Heating power consumption	0.41 kW	0.83 kW
min. / opt. / max. heating flow	1.1 / 1.6 / 1.9 A	2.4 / 3.2 / 3.6 A
Length approx.	305 mm	355 mm
Width approx.	260 mm	310 mm
Height approx.	285 mm	355 mm
Weight	9 kg	12 kg
Drying air connection	80 mm	100 mm
Moist air connection	38 / 50 mm	50 mm
Sound pressure level (within a distance of 1 m)	60 dB(A)	61 dB(A)

* at 20 °C/60% rh

Circuit diagram TTR 200

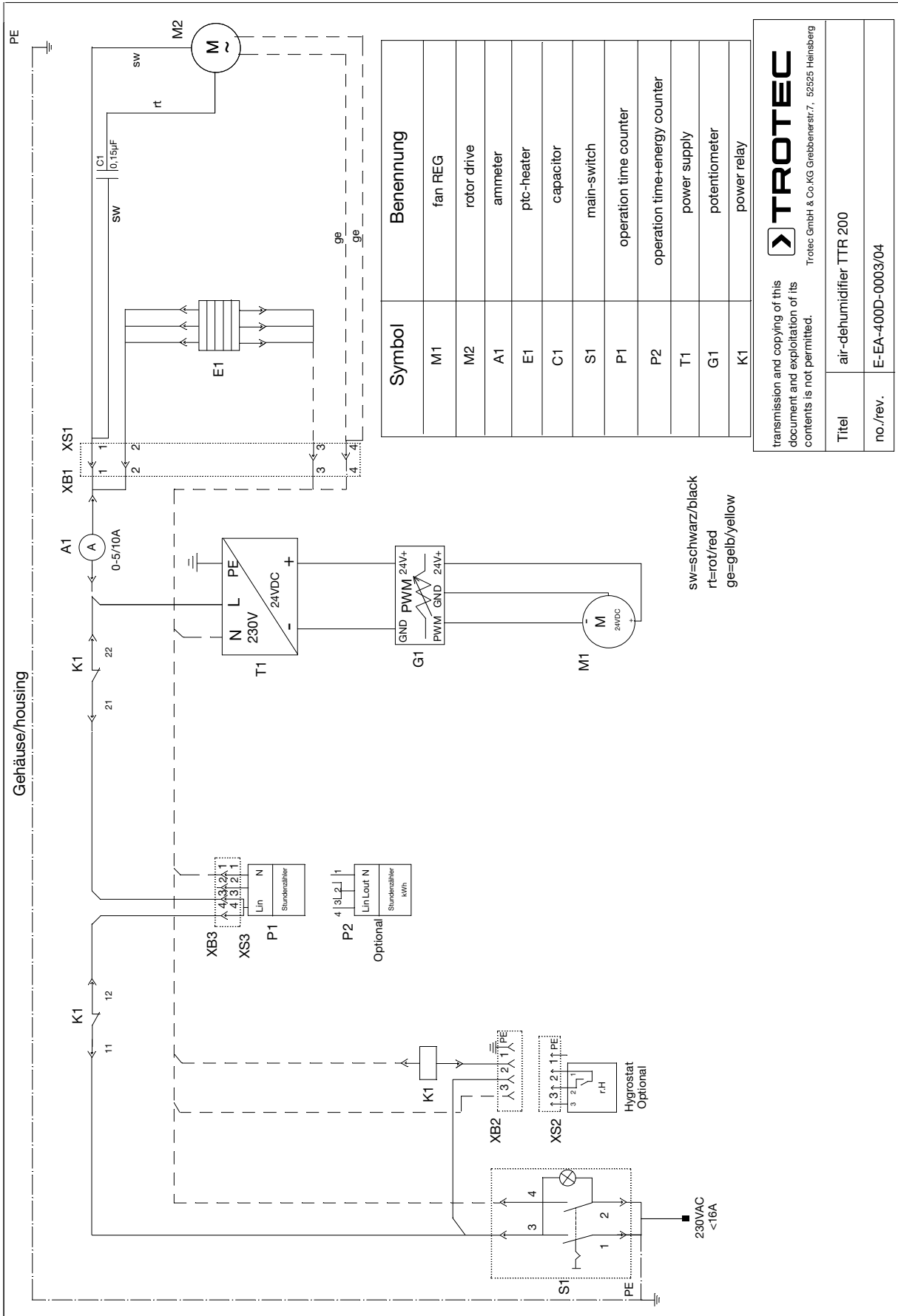

Symbol	Benennung
M1	fan REG
M2	rotor drive
A1	ammeter
E1	ptc-heater
C1	capacitor
S1	main-switch
P1	operation time counter
P2	operation time+energy counter
T1	power supply
G1	potentiometer
K1	power relay

TROTEC
Trotec GmbH & Co.KG Grebbenerstr.7, 52525 Heinsberg

transmission and copying of this document and exploitation of its contents is not permitted.

Titel	air-dehumidifier TTR 200
no./rev.	E-EA-400D-0003/04

Circuit diagram TTR 300

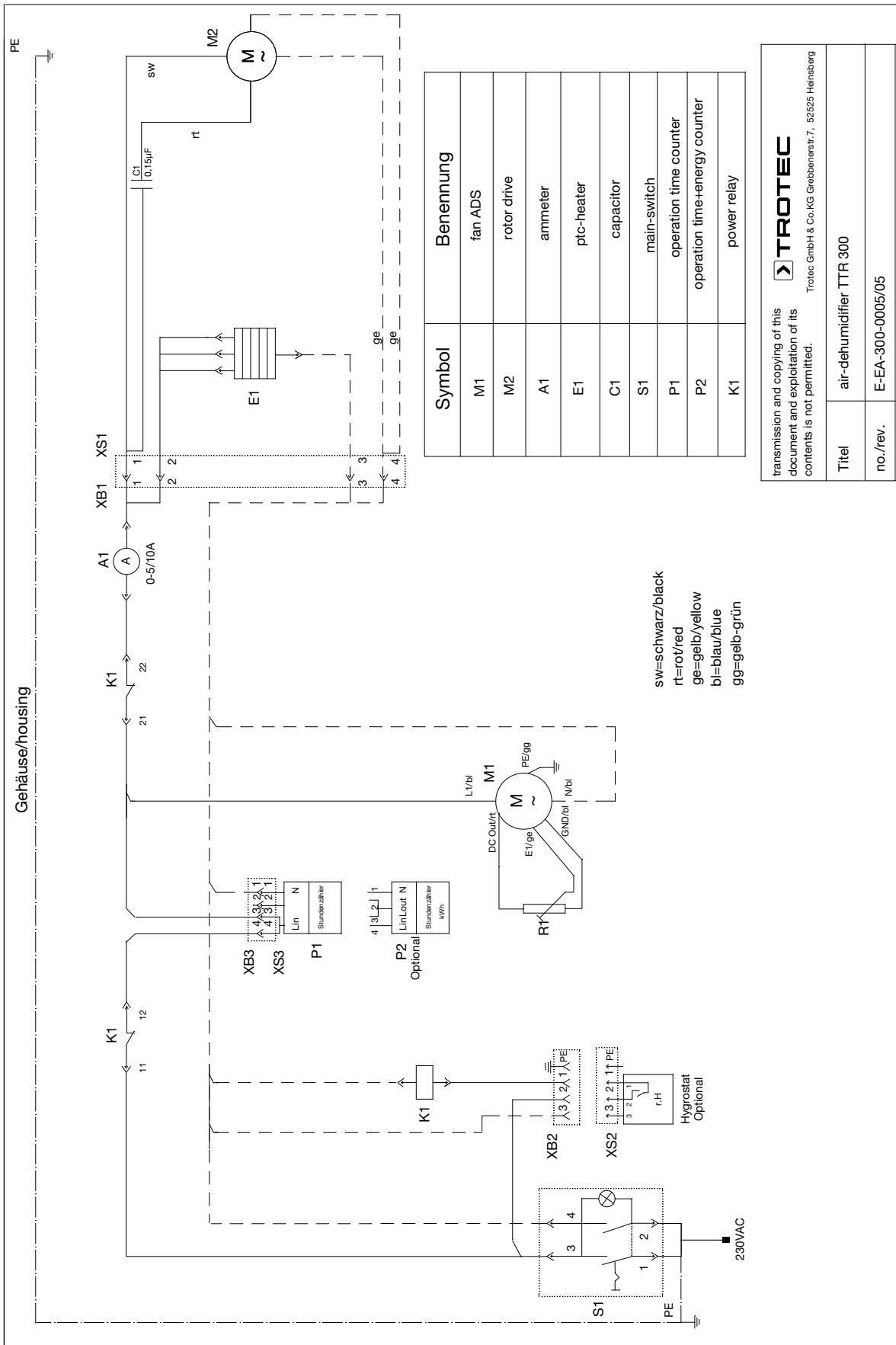

Dimensions TTR200

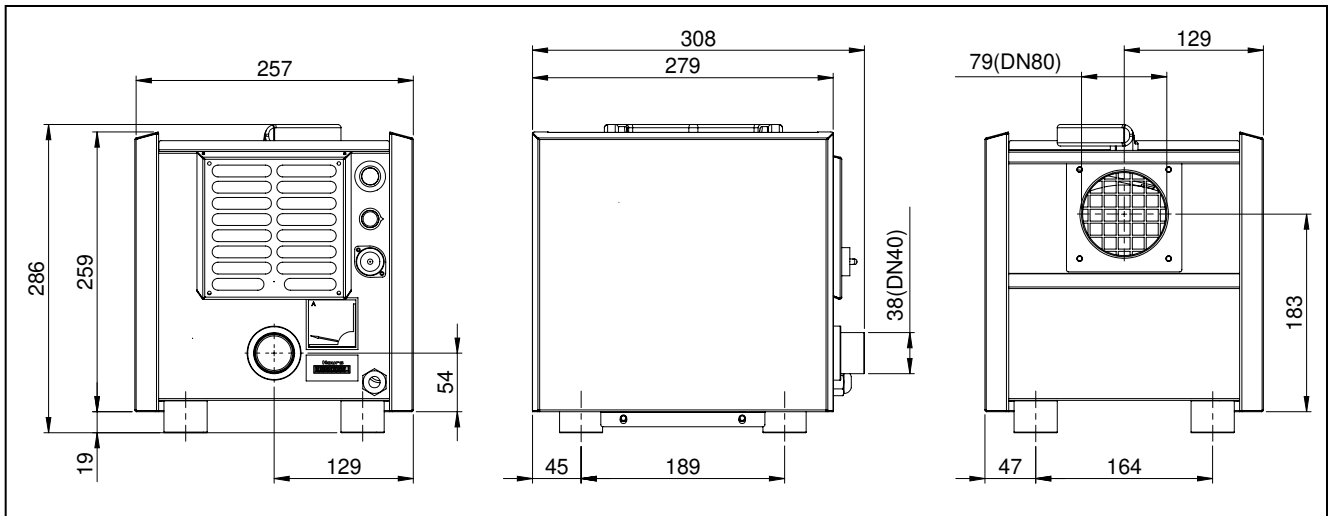

Dimensions TTR 300

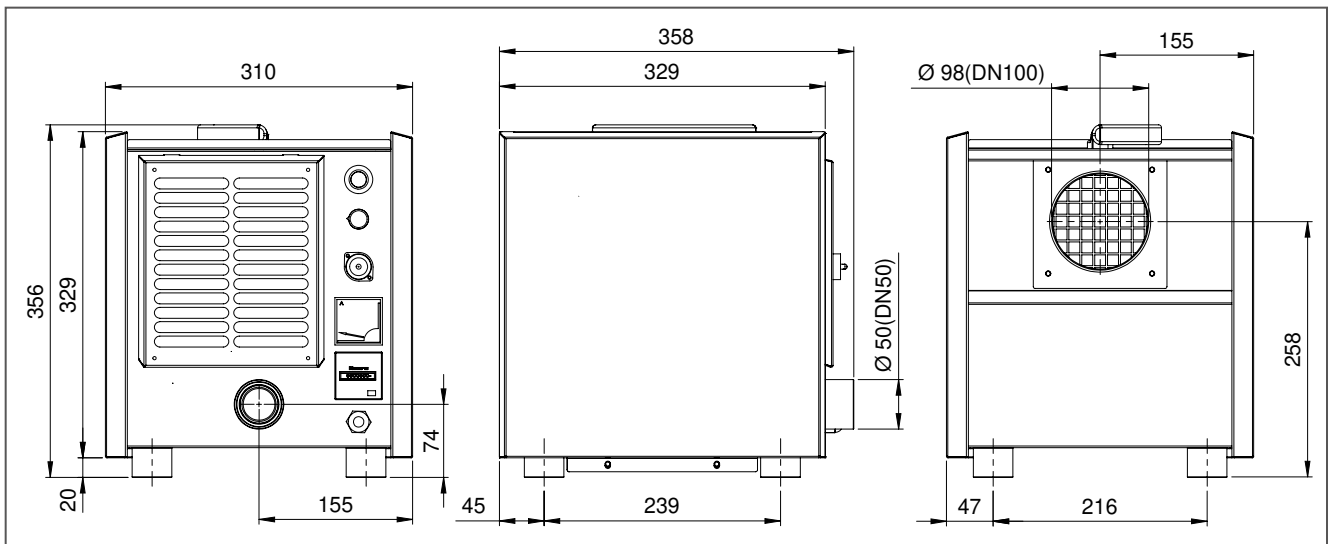

Spare parts TTR 200

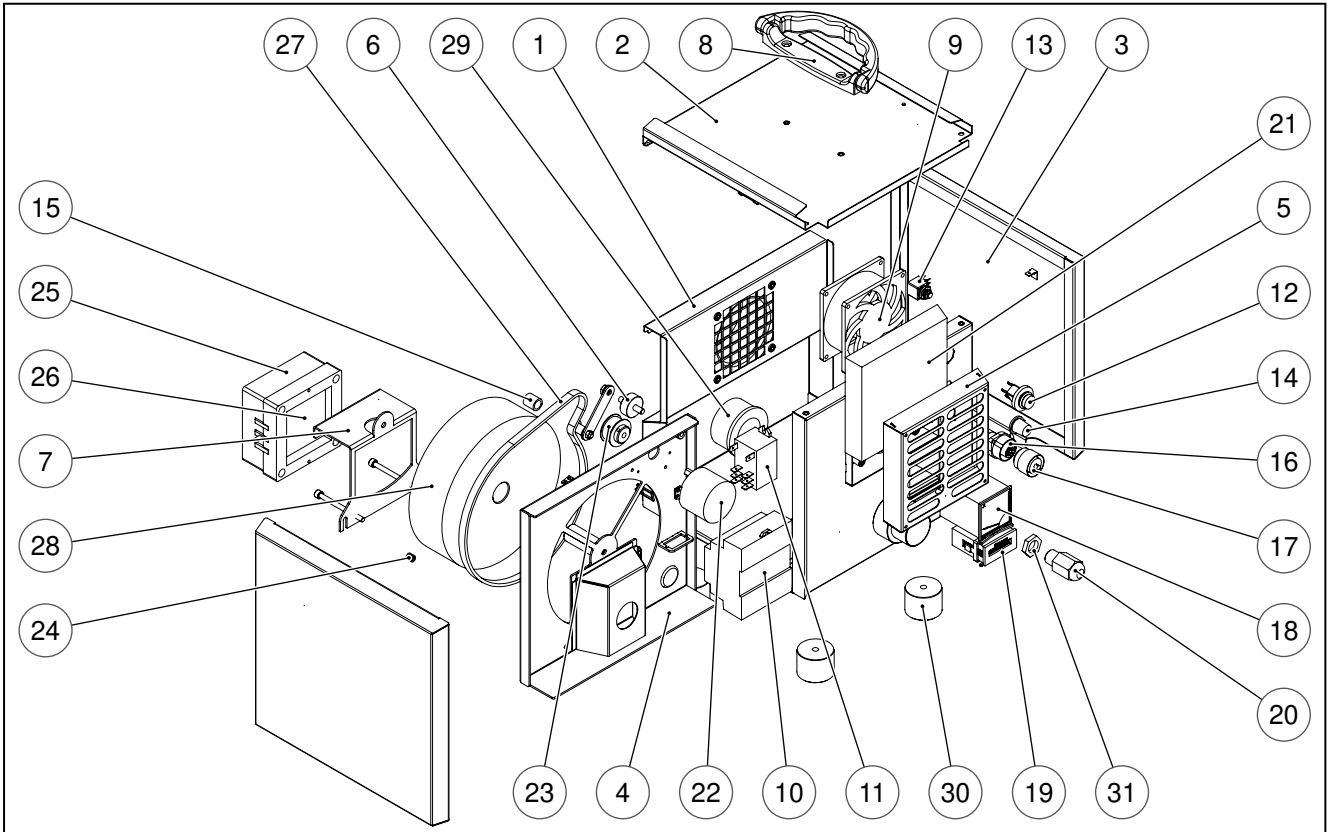

Item	Designation	Article number
1	Housing	P 1000 1241
2	Cover	P 1000 1241
3	Panel	P 1000 1241
4	Rotor cartridge	P 1000 1241
5	ADS filter hood	P 1000 1241
6	Clamping rubber	P 1000 1059
7	Heating frame	P 1000 1241
8	Handle	P 1000 1246
9	Fan	P 1000 0536
10	Power supply	P 1000 1208
11	Relay	P 1000 0195
12	Switch	P 1000 1376
13	Speed controller	P 1000 0291
14	Rotary knob for potentiometer	P 1000 1250
15	Needle bush	P 1000 1061

Item	Designation	Article number
16	Connection socket	P 1000 1049
17	Protective cover	P 1000 1053
18	Ampere meter	P 1000 1058
19	Operating hour counter	P 1000 1245
20	Cable bushing	P 1000 1247
21	Filter mat	P 1000 0670
22	Gear motor	P 1000 1160
23	Toothed belt disc	P 1000 1239
24	Compression spring	P 1000 1055
25	Heating consumption	P 1000 1270
26	Heating element	P 1000 1268
27	Toothed belt	P 1000 1258
28	Rotor	P 1000 1218
29	Rubber sleeve	6100009046
30	Device stand	P 1000 0425
31	Counter nut cable bushing	P 1000 1248

Spare parts TTR 300

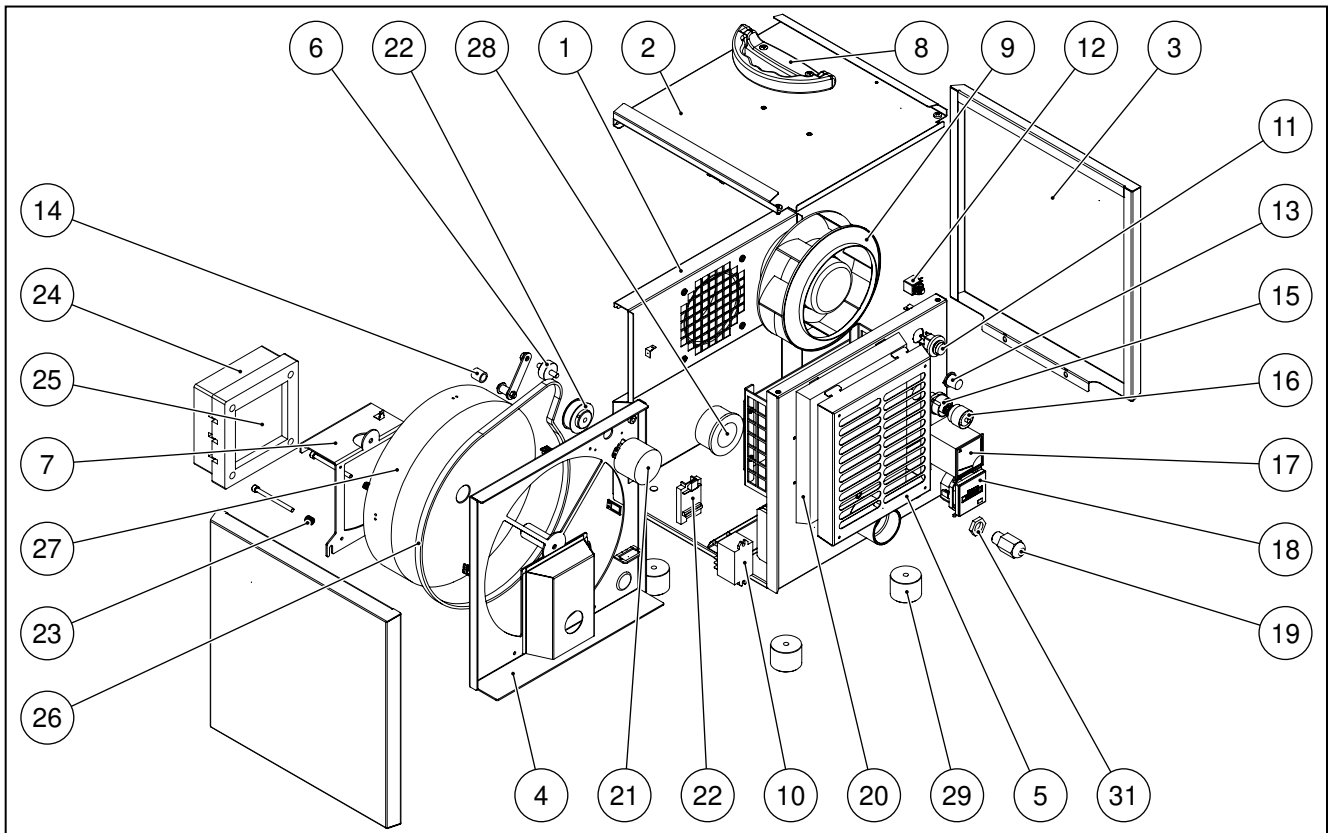

Item	Designation	Article number
1	Housing	P 1000 1242
2	Cover	P 1000 1242
3	Panel	P 1000 1242
4	Rotor cartridge	P 1000 1242
5	ADS filter hood	P 1000 1242
6	Clamping rubber	P 1000 1059
7	Heating frame	P 1000 1242
8	Handle	P 1000 1246
9	Fan	P 1000 0576
10	Relay	P 1000 0195
11	Switch	P 1000 1376
12	Potentiometer	P 1000 1751
13	Rotary knob for potentiometer	P 1000 1250
14	Needle bush	P 1000 1061
15	Connection socket	P 1000 1049
16	Protective cover	P 1000 1053

Item	Designation	Article number
17	Ampere meter	P 1000 1058
18	Operating hour counter	P 1000 1137
19	Cable bushing	P 1000 1247
20	Filter mat	P 1000 0650
21	Gear motor	P 1000 1160
22	Toothed belt disc	P 1000 1240
23	Compression spring	P 1000 1055
24	Heating consumption	P 1000 1269
25	Heating element	P 1000 1276
26	Toothed belt	P 1000 1065
27	Rotor	P 1000 1036
28	Rubber sleeve	6100009046
29	Device stand	P 1000 0425
30	Relay mounting clip	P 1000 0196
31	Counter nut cable bushing	P 1000 1248



EC Declaration of Conformity

TROTEC® GmbH & Co. KG

Grebbener Straße 7
D-52525 Heinsberg

hereby declares that the dryers described below are in conformity with the EU guidelines stated herein with respect to their conception and construction, as well as the type of model placed on the market.

Important notice:

Any improper use, installation, servicing etc. or any unauthorised alterations carried out on the factory-made appliance render this declaration null and void.

Type of model:**Desiccant Dehumidifier****Series:****TTR series****Applicable regulations:**

2006/42/EC
2004/108/EC
2011/65/EC

Machinery Directive
EMC Directive
RoHS

Applied harmonised standards:

EN 12100:2010
EN 60204-1
EN 60335-1
EN 60335-2-40:2003 + A11:2004 + A12:2005 + A1:2006
EN 55011:2009 + A1:2010
EN 61000-3-2:2006 + A1:2009 + A2:2009
EN 61000-3-3:2008

Author and authorised party of the technical documentation:
Trotec GmbH & Co. KG · Grebbener Straße 7 · D-52525 Heinsberg
Phone: +49 2452 962-400 · Fax: +49 2452 962-200 · Email: info@trotec.com

Heinsberg, 01 September 2014

Managing director: Detlef von der Lieck

Trotec GmbH & Co. KG

Grebener Str. 7
D-52525 Heinsberg

☎ +49 2452 962-400

☎ +49 2452 962-200

info@trotec.com

www.trotec.com